

## Demolition Hammer - 3 611 C38 5K0 - GSH 500

www.powertools-aftersaleservice.com



**BOSCH**

Item	Part Number	Description	Illustration	Price	Quantity	Price Group
1	1 619 P10 301	Motor Housing	1	-,-	1	28
2	1 619 P08 301	Field 230V	1	-,-	1	34
4	1 619 P09 019	Switch	1	-,-	1	26
6	1 610 703 053	Grommet Ø9,7-Ø12x89 MM	1	-,-	1	13
7	1 601 302 019	Fastening Clamp	1	-,-	1	11
13	1 610 900 026	Deep-Groove Ball Bearing 8x24x8	1	-,-	1	24
14	1 610 905 041	Deep-Groove Ball Bearing 12x32x10	1	-,-	1	23
15	1 616 610 085	Fan	1	-,-	1	14
19	2 910 211 019	Tapping Screw DIN 7971-ST3,9x16-F	1	-,-	1	10
22	1 619 P08 758	Protection Sleeve	1	-,-	1	24
24	1 619 P12 374	Dust Cap	1	-,-	1	16
25	1 903 230 016	Ball 10 MM III DIN 5401ST	1	-,-	3	15
27	1 619 P09 017	Air-Deflector Ring	1	-,-	1	13
28	1 619 P08 759	Compression Spring	1	-,-	1	11
30	1 619 P08 760	Supporting Disc	1	-,-	1	11
32	1 619 P08 761	Damping Ring	1	-,-	1	10
34	1 610 516 013	Flange	1	-,-	1	12
43	1 619 P08 767	Fan Cover	1	-,-	1	20
53	1 619 P08 768	Washer	1	-,-	1	20
57	1 619 P08 772	Striker	1	-,-	1	19
69	1 610 099 004	Retaining Bracket	1	-,-	1	13
72	1 619 P07 766	Eccentric Cog Wheel	1	-,-	1	36
73	1 619 P08 776	Housing Cover	1	-,-	1	22
74	1 619 P08 777	Holding-Down-Appliance	1	-,-	1	12
75	1 619 P08 778	Handle	1	-,-	1	24
76	1 613 435 015	Torx Oval-Head Screw M5x12-TORX,T25 SILVER	1	-,-	1	11
81	1 619 P08 780	Handle Cover	1	-,-	1	18
84	1 612 025 060	Auxiliary Handle M8 BLACK	2	-,-	1	20
86	1 613 490 002	T-Head Bolt M8x40 MM	2	-,-	1	13
87	1 611 316 019	Clamping Band Ø62 MM	2	-,-	1	16
95	1 610 210 173	O-Ring 32,0x1,5 MM	1	-,-	1	11
104	1 619 P08 783	Seal ring	1	-,-	2	11
111	1 610 290 064	Bushing	1	-,-	1	11

Item	Part Number	Description	Illustration	Price	Quantity	Price Group
112	1 613 300 008	Hex Nut DIN 936-M8x1-8	1	-,-	1	11
113	1 613 435 009	Tapping Screw ST-4,8x57,5-TORX,T20	1	-,-	2	11
117	1 610 913 004	Needle-Roller Assembly Ø13 MM	1	-,-	2	16
129	1 619 P10 302	Cover Sleeve	1	-,-	1	22
138	1 619 P08 785	Sealing Frame	1	-,-	1	11
141	1 610 290 066	Rotary shaft lip seal	1	-,-	1	22
143	1 619 P08 752	Retainer	1	-,-	1	11
145	1 610 119 012	Spring retaining ring	1	-,-	1	11
154	2 916 660 019	Spring retaining ring DIN 472-42x1,75MM	1	-,-	1	16
160	1 619 P08 787	Damping Ring	1	-,-	1	11
161	1 619 P08 788	Damping Ring	1	-,-	1	11
162	1 619 P08 789	O-Ring	1	-,-	1	11
163	1 610 290 065	Seal ring	1	-,-	1	17
165	1 619 P08 791	O-Ring	1	-,-	1	11
168	1 619 P08 792	O-Ring	1	-,-	2	10
171	1 613 435 014	Torx Oval-Head Screw M5x16-TORX,T25 SILVER	1	-,-	4	11
172	1 613 435 013	Torx Oval-Head Screw M6x30-TORX,T30 SILVER	1	-,-	8	11
173	1 619 P01 380	Screw 4x14	1	-,-	2	10
174	1 613 435 012	Torx Oval-Head Screw M4,8x25-TORX,T25 SILVER	1	-,-	4	11
175	2 912 401 018	Tapping Screw DIN7981-ST3,9x13-C-Z	1	-,-	4	10
176	1 613 435 012	Torx Oval-Head Screw M4,8x25-TORX,T25 SILVER	1	-,-	2	11
177	1 603 435 051	Tapping Screw ST3,9x32 SILVER	1	-,-	2	11
178	1 619 P10 286	Connecting Cable	1	-,-	1	19
179	1 619 P07 815	Screw	1	-,-	2	10
183	1 619 P09 862	Felt Seal	1	-,-	1	10
803	1 619 P09 697	Armature 230V	1	-,-	1	41
805	1 607 000 227	Power supply cord EU 4,15m 2 x 1,0mm H07 RN-F	1	-,-	1	31
811	1 617 014 138	Carbon-Brush Set	1	-,-	1	28
817	1 614 652 004	Spiral Spring	1	-,-	2	20
823	1 619 P09 699	Toolholder	1	-,-	1	37
839	1 619 P09 700	Gear Housing	1	-,-	1	35
840	1 619 P09 701	Impact Mechanism Housing	1	-,-	1	41
841	1 619 P09 707	Striker Pin	1	-,-	1	30
854	1 619 P09 702	Stop Disc	1	-,-	1	21
856	1 619 P09 703	Hammer Piston	1	-,-	1	24
884	1 612 025 055	Auxiliary Handle Ø62 MM BLACK	2	-,-	1	36
885	1 618 040 074	index turning toolholder	2	-,-	1	17
886	1 617 000 459	Auxiliary Handle M8 BLACK	2	-,-	1	25
898	1 619 P12 628	Wear and Tear Part Set	N/A	-,-	1	36

Lubrication instructions for product: Demolition Hammer - 3 611 C38 5K0 - GSH 500

Pos.	Description	Instruction	Lubricant	Quantity
13	Deep groove ball bearing	Grease	1.615.430.002 Bosch	
25 (823)	Ball	Grease	1.615.430.002 Bosch	
839	Gearbox housing	Fill	1 615 430 015 Bosch	50ml
856	Hammer piston / connecting rod	Grease running surface	1 615 430 015 Bosch	1
72	Eccentric gear	Oil running surface	SAE 20 W Mineral oil (commercially available)	
73,74	Housing cover	Fill	1 615 430 015 Bosch	10
104,138,161,162 ,163,164,165,168	O-ring / sealing ring	Oil	SAE 20 W Mineral oil (commercially available)	

## Product information Demolition Hammer - 3 611 C38 5K0 - GSH 500

Product No	3 611 C38 5K0
Description	263.788; Demolition Hammer
DIN-Text	
ID_Text_Ext	0
Trading_Description	GSH 500
Voltage_1	230 V
ID_Country_Product	ASI

Illustration - Type E

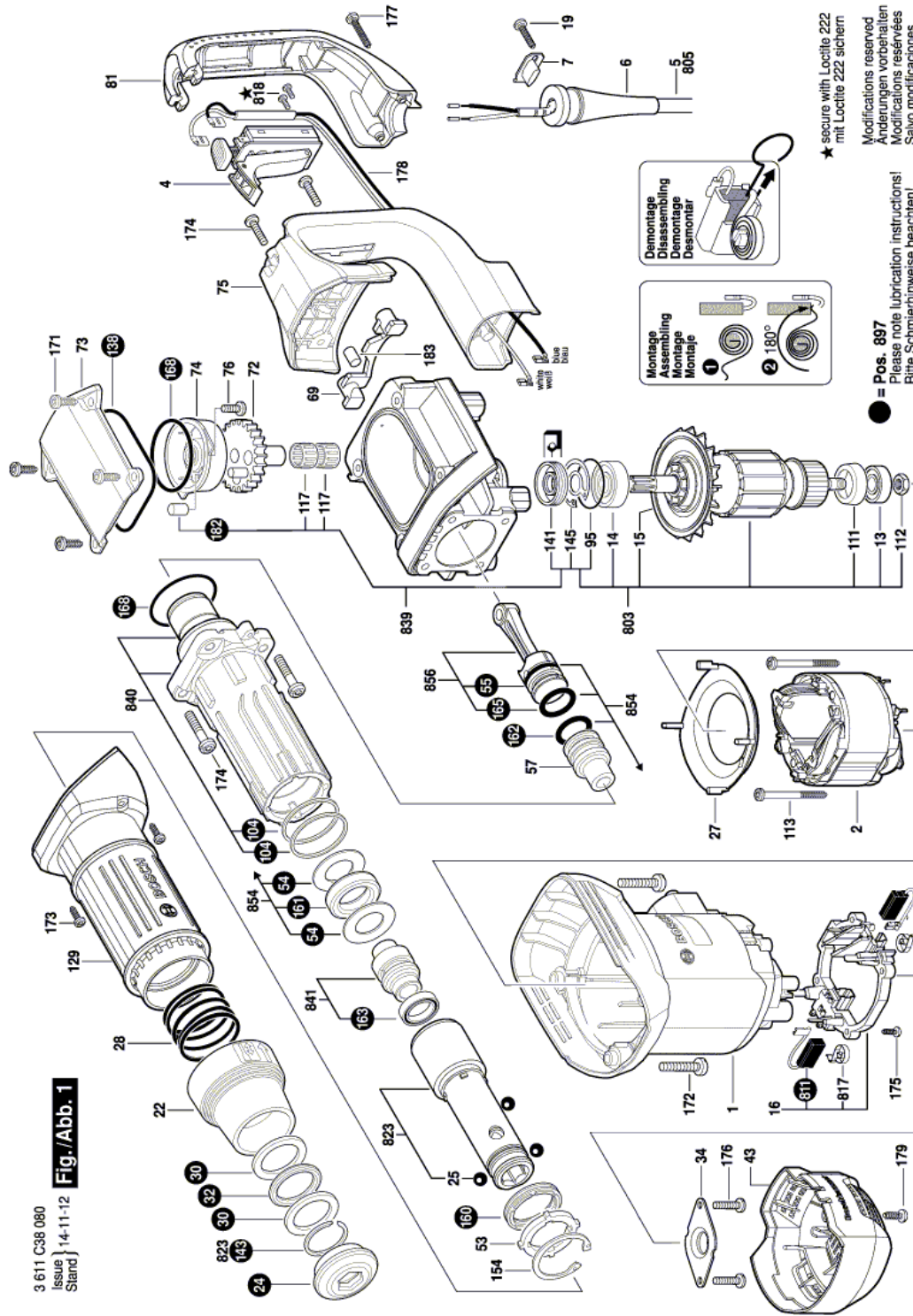
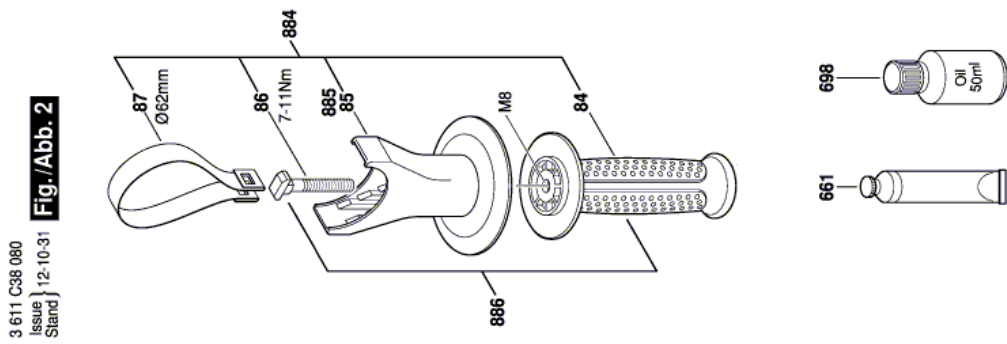

Illustration - Type E



Modifications reserved  
Änderungen vorbehalten  
Modificacions reservées  
Salvo modificaciones

Information subject to change without further notice.